



Service Information

Oil change kit for
ZF 5HP/6HP automatic transmission

Below is the official ZF factory Service Information for the various 5HP and 6HP models.

If you'd like to see how to completely change the fluid, filter and Mechatronics Valve Seals and Bridge Seal in a ZF 6HP26 transmission please check out my YouTube video series on it at:

<https://youtu.be/9zfMolveR-M>

And on my companion blog at Aston1936.com

Seeing how it's done makes the work a LOT easier.

Hope this helps you with your project!





Service Information

Oil change kit for ZF 5HP/6HP automatic transmission



CAUTION

**Risk of burns due to contact with hot oil.
Slight to moderate injury possible.**

- ⇒ Wear protective goggles.
- ⇒ Wear protective gloves.
- ⇒ Wear protective clothing.

NOTICE

Property damage due to electrostatic discharge (ESD) possible.

- ⇒ Observe ESD protection.
- ⇒ Do not touch the contacts.
- ⇒ Wear conductive workwear.
- ⇒ Use ESD transport.
- ⇒ Use ESD protective packaging.



NOTICE

Observe the following instructions to prevent damage to the transmission:

- Do **not** tow vehicle if transmission is without oil. Observe the vehicle manufacturer specifications.
- For cleaning only use clean, **lint-free** cloths.
- Do **not** start the engine if there is no oil in the transmission.
- Only use the specified **ZF-LifeguardFluid** (Tab. 1).
- Do not use any further additives as they alter the chemical composition of the oil!
- Adjust the oil level in the transmission exactly according to filling regulations. If the oil level is too low, the transmission will be damaged. If the oil level is too high, the excess oil will leak from the transmission through the overflow when heated. The escaping oil can ignite on hot parts (e.g. exhaust system).
- Adhere to the bolting sequence (Fig. 1).
- Observe tightening torques (Tab. 2 - 14).



Before changing the oil: Read instructions carefully. Check which version (A / B / C) applies to the oil change (Table 1).



ZF automatic transmissions are filled with specially developed semi-synthetic oils. At very high operating temperatures, the oil ages faster than under normal conditions.

Examples:

- Many trips at high speeds
- Many trips while towing a trailer
- Sporty driving

Depending on the driving style, ZF recommends a transmission oil change every 80,000 to 120,000 km or after eight years at the latest.



www.zf.com/serviceinformation



Service Information

Oil change kit for ZF 5HP/6HP automatic transmission





Assignment of Oil change kits									
Kit	Transmission		Oil pan		Oil	Version ²			
Art.-Nr.			Metal	Plastic	ZF LifeguardFluid	A	B	C	Tab.
8700 000	5HP19	Alpina	x		5	x			
		BMW	x		5	x			
8700 001	5HP19 FL	Audi	x		5	x			
		Porsche	x		5	x			
		Skoda	x		5	x			
		Volkswagen	x		5	x			
	5HP19 FLA	Audi	x		5	x			
		Volkswagen	x		5	x			
8700 002	5HP24	Alpina	x		5	x			
		BMW	x		5	x			
		Jaguar	x		5	x			
		Land Rover	x		5	x			
8700 003	5HP24 A	Audi	x		5	x			
8700 004	5HP30	Alpina	x		5	x			
		Aston Martin	x		5	x			
		Bentley	x		5	x			
		BMW	x		5	x			
		Rolls-Royce	x		5	x			
8700 250	6HP19	BMW		x	6			x	3
	6HP19 X			x	6			x	3
	6HP21			x	6			x	3
	6HP21 X			x	6			x	3
8700 251	6HP19 A	Audi	x		8			x	4
		Volkswagen	x		8			x	4
8700 252	6HP26	BMW		x	6	x			5
		Ford		x	6	x			
		Hyundai		x	6	x			
		Jaguar		x	6	x			6
		Lincoln		x	6	x			
	6HP26 X	Alpina		x	6	x			
		Aston Martin		x	6	x			
		BMW		x	6	x			7
		Ford		x	6	x			
		Land Rover		x	6	x			8
	6HP28	Alpina ¹		x	6			x	
		BMW		x	6			x	9
		Jaguar ¹		x	6			x	
		Wiesmann ¹		x	6			x	
	6HP28 X	Alpina		x	6			x	
		BMW ¹		x	6			x	10
		Land Rover		x	6			x	
	6HP32	Bentley		x	6		x		
		BMW		x	6		x		11
		Rolls-Royce		x	6		x		



Service Information

Oil change kit for ZF 5HP/6HP automatic transmission

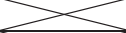

Assignment of Oil change kits									
Kit	Transmission		Oil pan		Oil	Version ²			
Art.-Nr.			Metal	Plastic	ZF LifeguardFluid	A	B	C	Tab.
8700 253	6HP26 X	BMW	x		6	x			12
		Lincoln	x		6	x			
	6HP32	BMW	x		6	x			
8700 254	6HP26 A61	Audi	x		6	x			13
		Bentley	x		6	x			13
8700 255	6HP28 AF	Audi	x		8		x		14

Tab. 1: Assignment of Oil change kits

¹ Versions with thermostat valve: The transmission oil temperature must reach at least 75°C during the test drive after an oil change (thermostat valve opens). After the test drive, allow the transmission to cool and check the oil level again at 35°C oil temperature.

² Select oil change procedure, see flowchart on Page 6



Service Information

Oil change kit for ZF 5HP/6HP automatic transmission

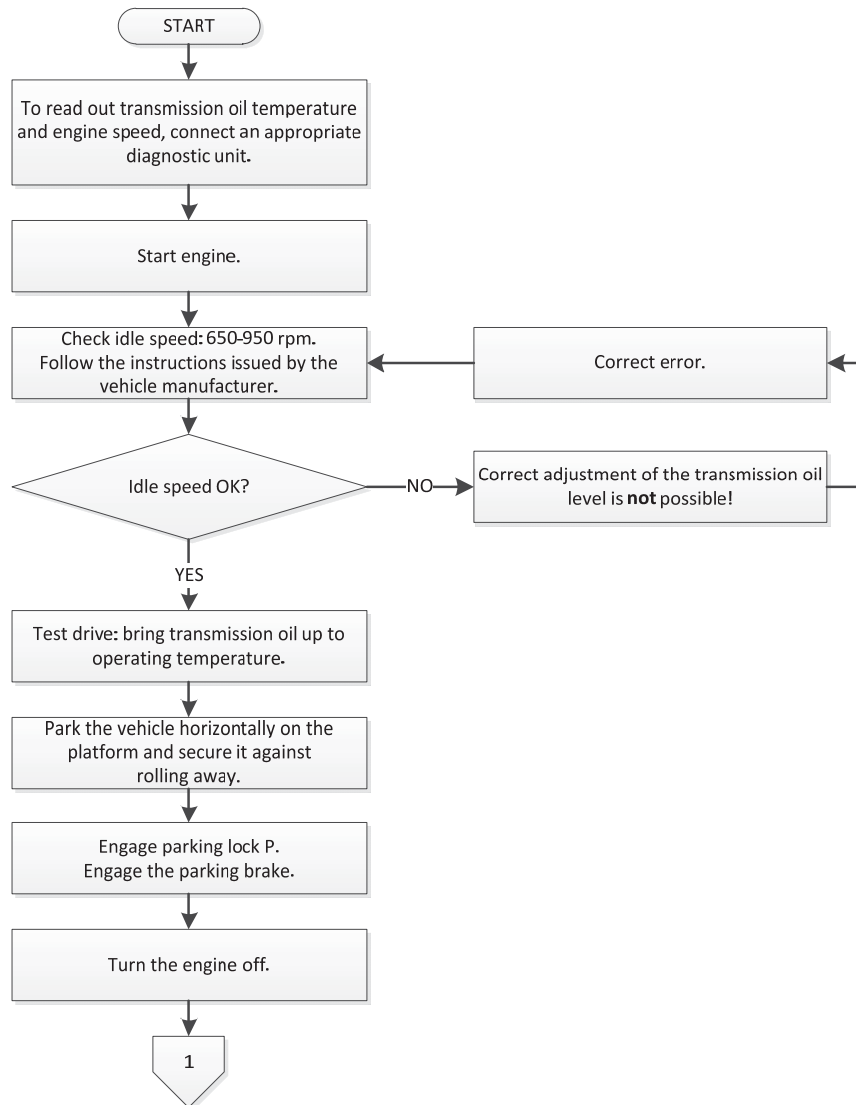



Service Information

Oil change kit for ZF 5HP/6HP automatic transmission



CAUTION
 Risk of injury to skin and eyes from hot components and hot liquids.
 Burns and scalds are possible.
 Always wear safety goggles, protective gloves, and protective clothing!

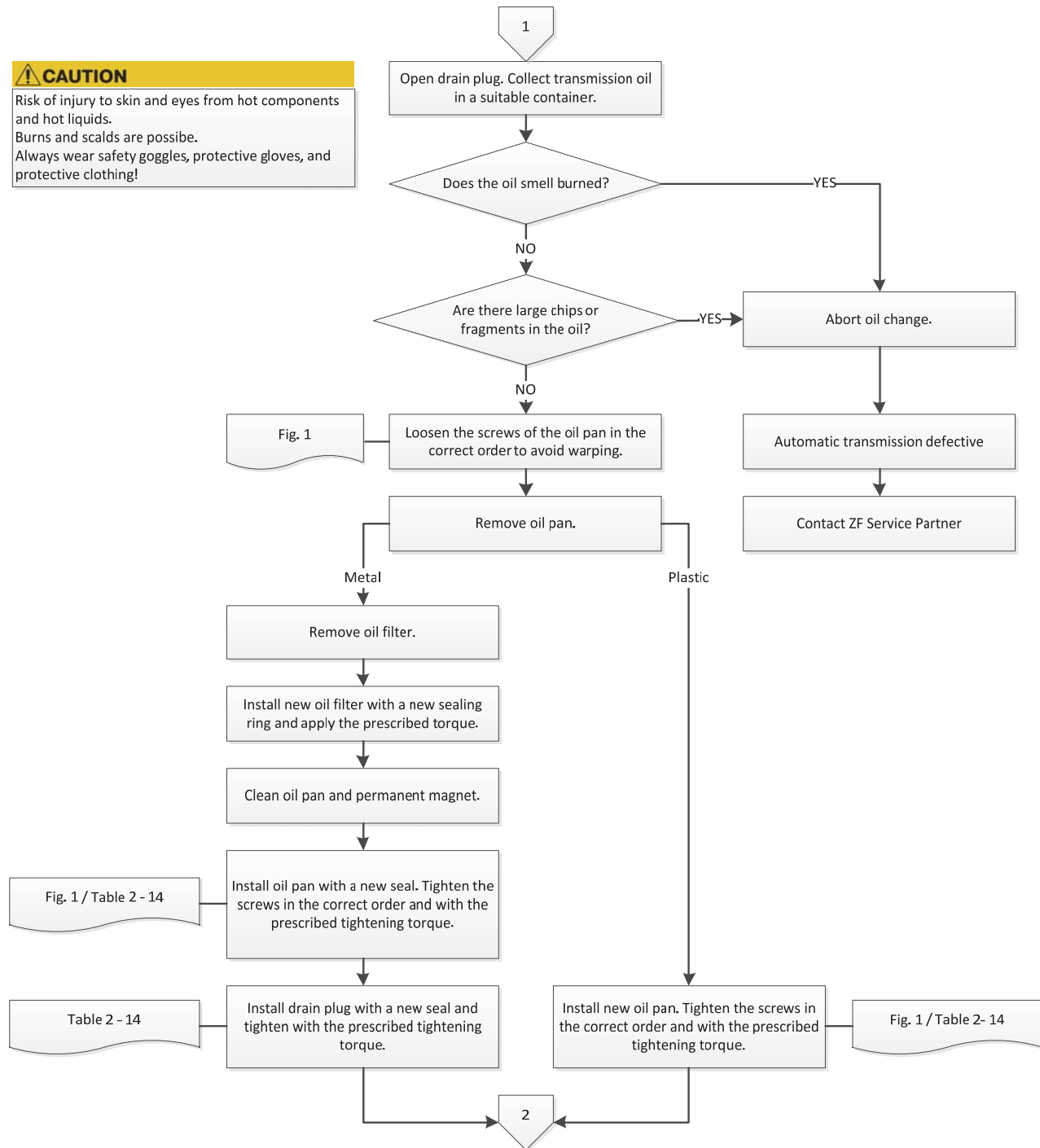



Service Information

Oil change kit for ZF 5HP/6HP automatic transmission

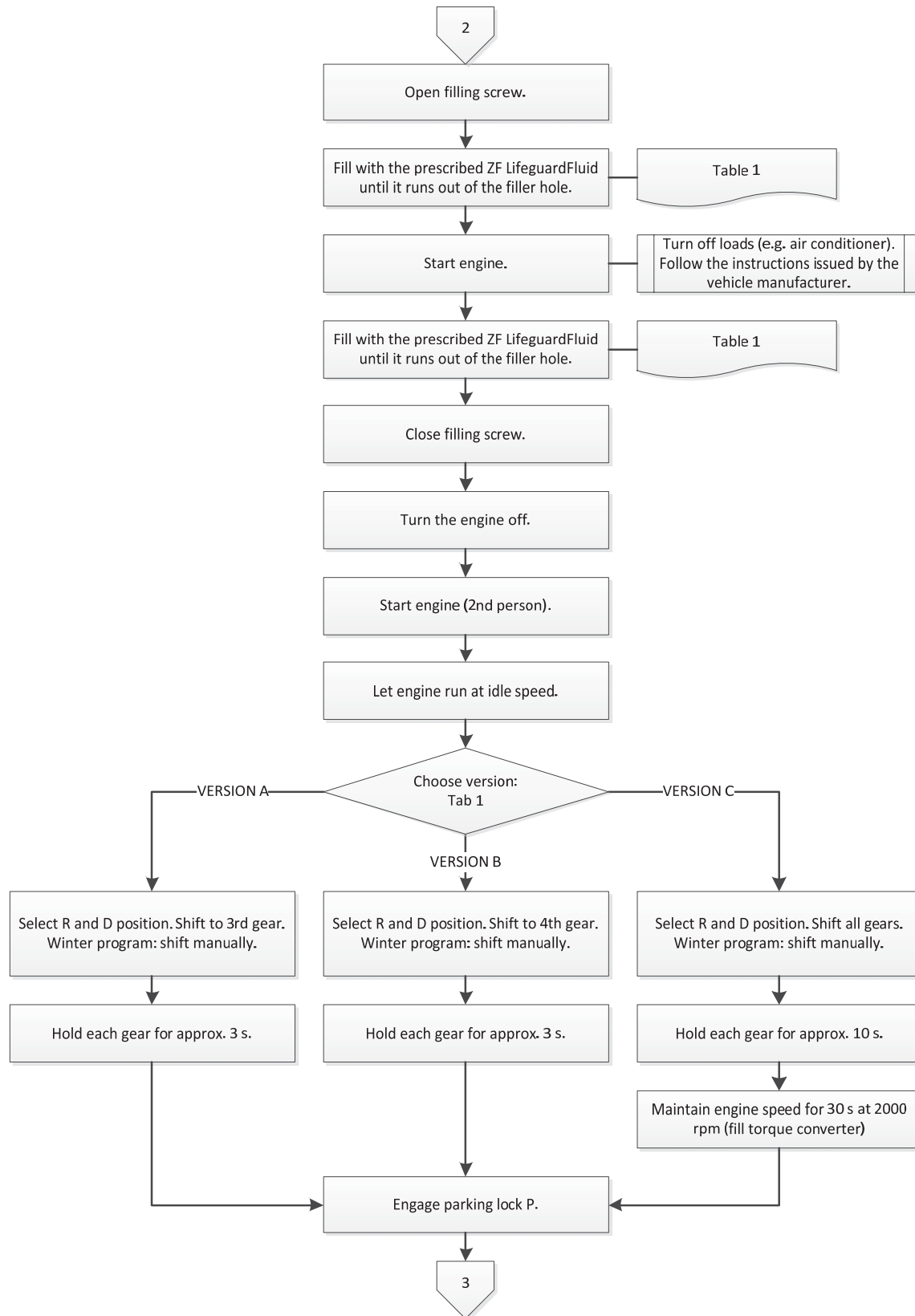



Service Information

Oil change kit for ZF 5HP/6HP automatic transmission

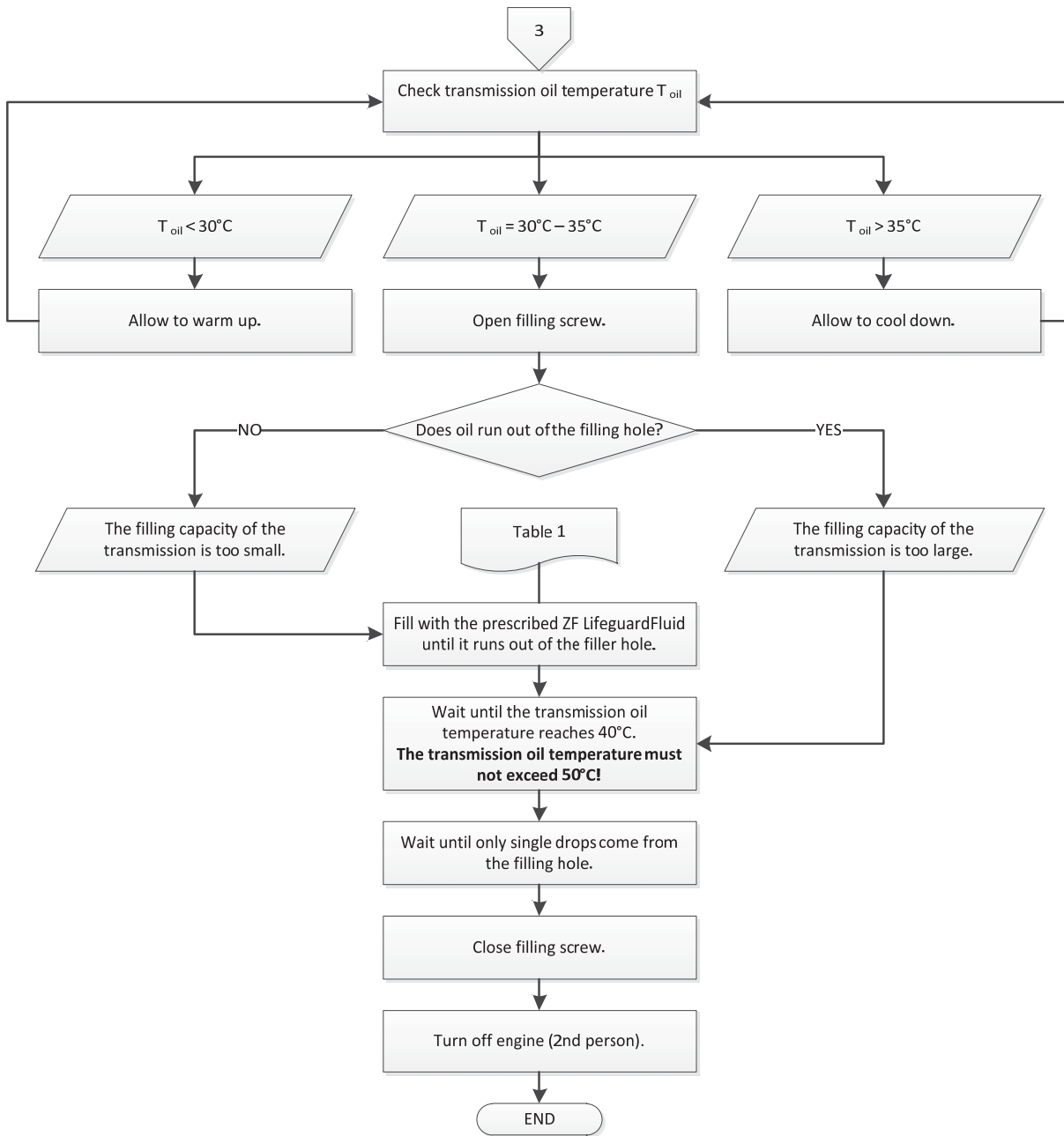



Service Information

Oil change kit for ZF 5HP/6HP automatic transmission

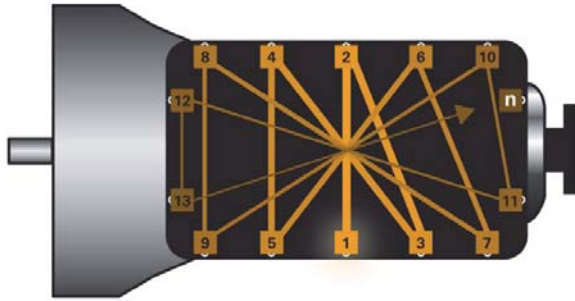
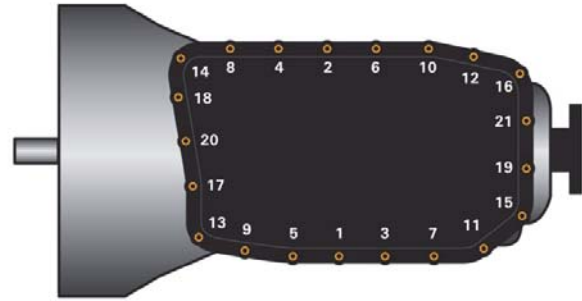

Fig 1: Schematic representation of the bolting sequence



Example: Bolting sequence



Loosen or tighten oil pan bolts: crosswise from the center outwards (Fig. 1).
First screw in the bolts by hand, then tighten in the correct order with the correct torque. Follow the instructions issued by the vehicle manufacturer.

	Oil pan		
Material	Aluminium	Plastic	Steel plate
Tightening torque	4 Nm + 45°	10 Nm	12 Nm
Oil filter	Separate part	Integrated in oil pan	Separate part

Tab. 2: Tightening torque



Service Information

Oil change kit for ZF 5HP/6HP automatic transmission



6HP19 / 6HP19 X / 6HP21 / 6HP21 X (BMW)

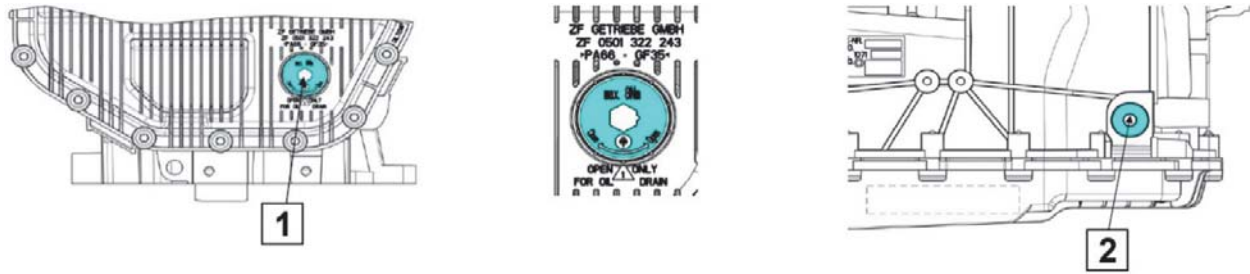

	(1)	(2)
	Drain plug	Filler plug
Dimensions	M 24 x 1	M 18 x 1,5
Hexagon socket	10 mm	8 mm
Tightening torque	8 Nm	35 Nm ± 3,5 Nm

Tab. 3: 6HP19 / 6HP19 X / 6HP21 / 6HP21 X (BMW)

6HP19 A (Volkswagen)

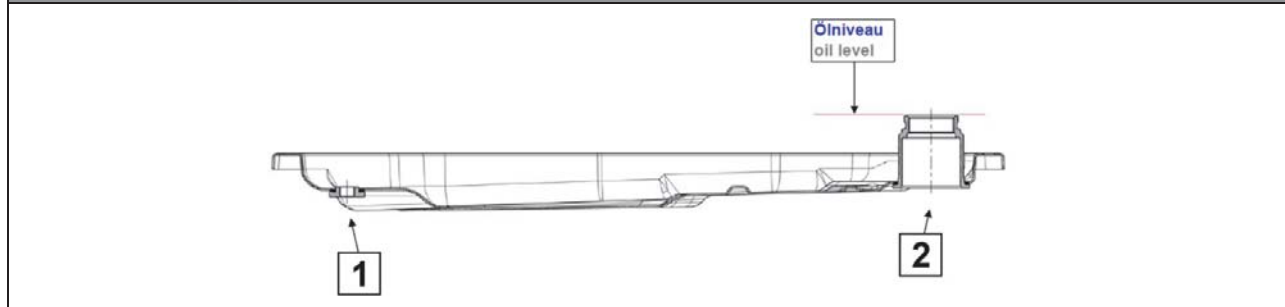

	(1)	(2)
	Drain plug	Filler plug
Dimensions	M 10 x 1	M 30 x 1,5
Hexagon socket	5 mm	17 mm
Tightening torque	12 Nm ± 1,2 Nm	80 Nm ± 8 Nm

Tab. 4: 6HP19 A (Volkswagen)

6HP26 (BMW)

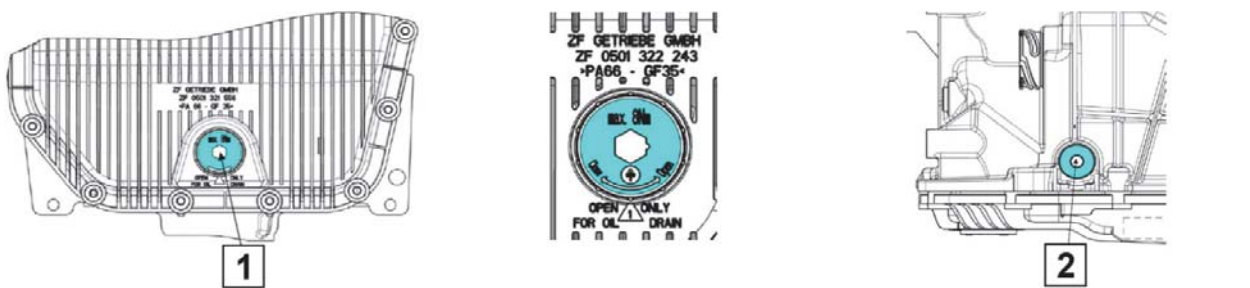

	(1)	(2)
	Drain plug	Filler plug
Dimensions	M 24 x 1	M 18 x 1,5
Hexagon socket	10 mm	8 mm
Tightening torque	8 Nm	35 Nm ± 3,5 Nm

Tab. 5: 6HP26 (BMW)



Service Information

Oil change kit for ZF 5HP/6HP automatic transmission



6HP26 (Jaguar)

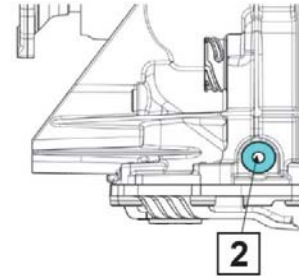
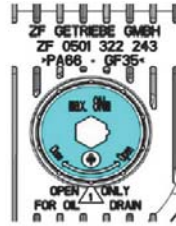
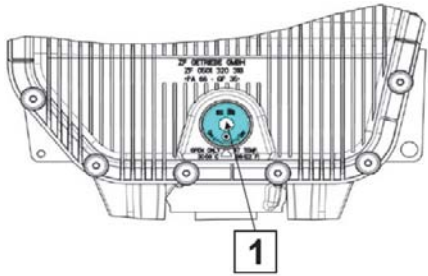

	(1)	(2)
	Drain plug	Filler plug
Dimensions	M 24 x 1	M 18 x 1,5
Hexagon socket	10 mm	8 mm
Tightening torque	8 Nm	35 Nm ± 3,5 Nm

Tab. 6: 6HP26 (Jaguar)

6HP26 X (BMW)

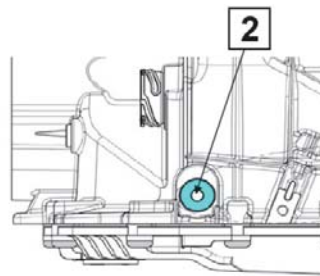
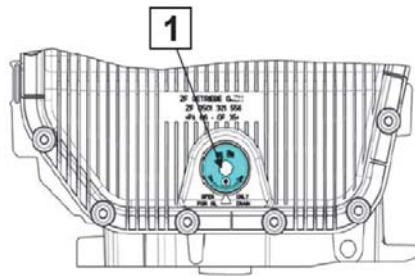

	(1)	(2)
	Drain plug	Filler plug
Dimensions	M 24 x 1	M 18 x 1,5
Hexagon socket	10 mm	8 mm
Tightening torque	8 Nm	35 Nm ± 3,5 Nm

Tab. 7: 6HP26 X (BMW)

6HP26 X (Land Rover)

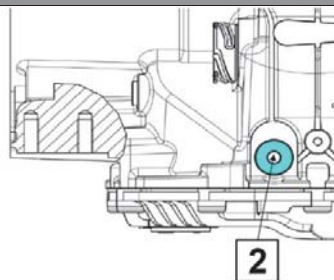
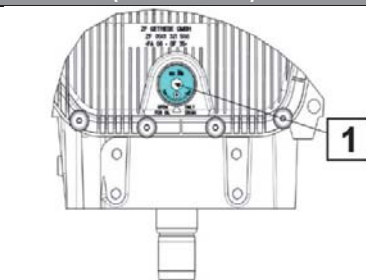

	(1)	(2)
	Drain plug	Filler plug
Dimensions	M 24 x 1	M 18 x 1,5
Hexagon socket	10 mm	8 mm
Tightening torque	8 Nm	35 Nm ± 3,5 Nm

Tab. 8: 6HP26 X (Land Rover)



Service Information

Oil change kit for ZF 5HP/6HP automatic transmission

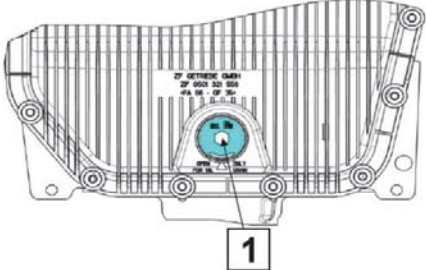
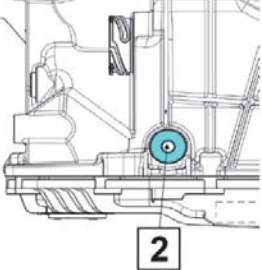

6HP28 (BMW)			
			
	(1)	(2)	
	Drain plug	Filler plug	
Dimensions	M 24 x 1	M 18 x 1,5	
Hexagon socket	10 mm	8 mm	
Tightening torque	8 Nm	35 Nm ± 3,5 Nm	

Tab. 9: 6HP28 (BMW)

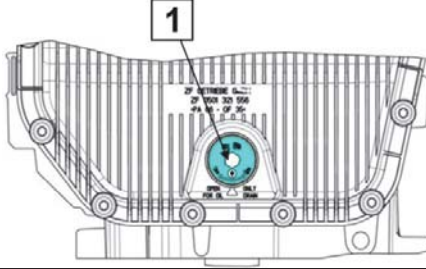
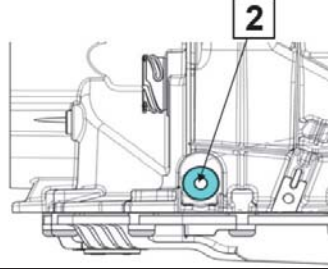
6HP28 X (BMW)			
			
	(1)	(2)	
	Drain plug	Filler plug	
Dimensions	M 24 x 1	M 18 x 1,5	
Hexagon socket	10 mm	8 mm	
Tightening torque	8 Nm	35 Nm ± 3,5 Nm	

Tab. 10: 6HP28 X (BMW)

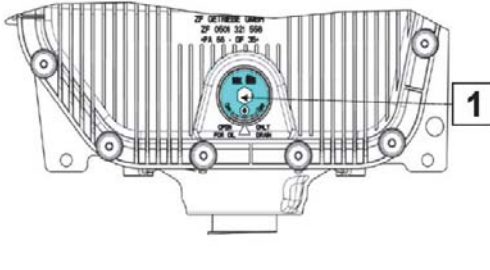
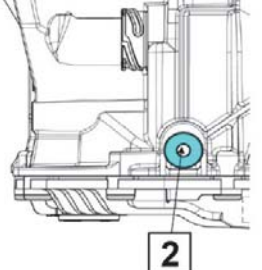
6HP32 (BMW)			
			
	(1)	(2)	
	Drain plug	Filler plug	
Dimensions	M 24 x 1	M 18 x 1,5	
Hexagon socket	10 mm	8 mm	
Tightening torque	8 Nm	35 Nm ± 3,5 Nm	

Tab. 11: 6HP32 (BMW)



Service Information

Oil change kit for ZF 5HP/6HP automatic transmission



6HP26 X (BMW)

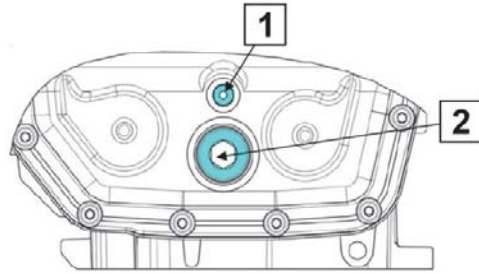

	(1)	(2)
	Drain plug	Filler plug
Dimensions	M 10 x 1	M 30 x 1,5
Hexagon socket	5 mm	17 mm
Tightening torque	12 Nm ± 1,2 Nm	80 Nm ± 8 Nm

Tab. 12: 6HP26 X (BMW)

6HP26 A61 (Audi / Bentley)

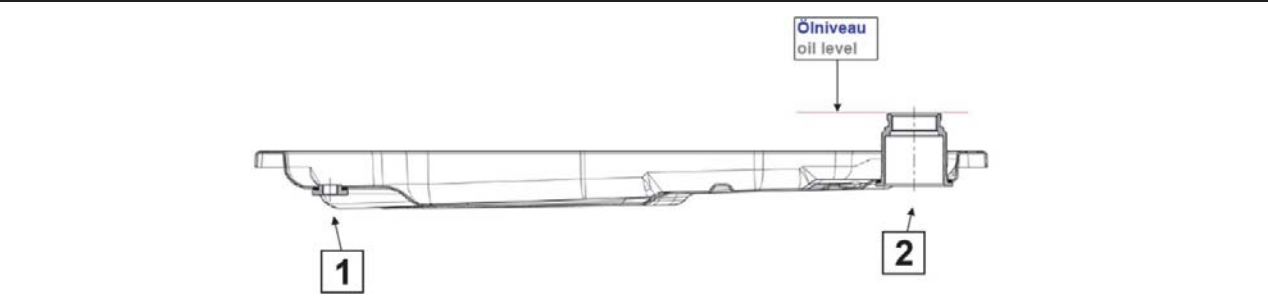

	(1)	(2)
	Drain plug	Filler plug
Dimensions	M 10 x 1	M 30 x 1,5
Hexagon socket	5 mm	17 mm
Tightening torque	12 Nm ± 1,2 Nm	80 Nm ± 8 Nm

Tab. 13: 6HP26 A61 (Audi / Bentley)

6HP28 AF (Audi)

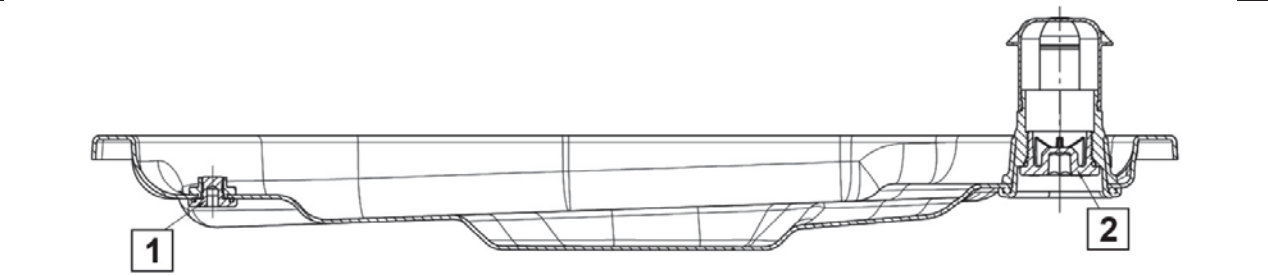

	(1)	(2)
	Drain plug	Filler plug
Dimensions	M 30 x 1,5	M 18 x 1,5
Hexagon socket	10 mm	5 mm
Tightening torque	8 Nm	12 Nm ± 1,2 Nm

Tab. 14: 6HP28 AF (Audi)